

# **Agilent Technologies Z5623A Option H01**

## **User's and Service Guide**

### **Dynamic Accuracy Test Set**



**Agilent Technologies**

**Manufacturing Part Number: Z5623-90001**

**Printed in USA**

**July 2007**

© Copyright Agilent Technologies, Inc. 2002, 2004-2007

---

## **Warranty Statement**

THE MATERIAL CONTAINED IN THIS DOCUMENT IS PROVIDED “AS IS,” AND IS SUBJECT TO BEING CHANGED, WITHOUT NOTICE, IN FUTURE EDITIONS. FURTHER, TO THE MAXIMUM EXTENT PERMITTED BY APPLICABLE LAW, AGILENT DISCLAIMS ALL WARRANTIES, EITHER EXPRESS OR IMPLIED WITH REGARD TO THIS MANUAL AND ANY INFORMATION CONTAINED HEREIN, INCLUDING BUT NOT LIMITED TO THE IMPLIED WARRANTIES OF MERCHANTABILITY AND FITNESS FOR A PARTICULAR PURPOSE. AGILENT SHALL NOT BE LIABLE FOR ERRORS OR FOR INCIDENTAL OR CONSEQUENTIAL DAMAGES IN CONNECTION WITH THE FURNISHING, USE, OR PERFORMANCE OF THIS DOCUMENT OR ANY INFORMATION CONTAINED HEREIN. SHOULD AGILENT AND THE USER HAVE A SEPARATE WRITTEN AGREEMENT WITH WARRANTY TERMS COVERING THE MATERIAL IN THIS DOCUMENT THAT CONFLICT WITH THESE TERMS, THE WARRANTY TERMS IN THE SEPARATE AGREEMENT WILL CONTROL.

---

## **DFARS/Restricted Rights Notice**

If software is for use in the performance of a U.S. Government prime contract or subcontract, Software is delivered and licensed as “Commercial computer software” as defined in DFAR 252.227-7014 (June 1995), or as a “commercial item” as defined in FAR 2.101(a) or as “Restricted computer software” as defined in FAR 52.227-19 (June 1987) or any equivalent agency regulation or contract clause. Use, duplication or disclosure of Software is subject to Agilent Technologies’ standard commercial license terms, and non-DOD Departments and Agencies of the U.S. Government will receive no greater than Restricted Rights as defined in FAR 52.227-19(c)(1-2) (June 1987). U.S. Government users will receive no greater than Limited Rights as defined in FAR 52.227-14 (June 1987) or DFAR 252.227-7015 (b)(2) (November 1995), as applicable in any technical data.

---

## Safety Notes

The following safety notes are used throughout this document. Familiarize yourself with each of these notes and its meaning before performing any of the procedures in this document.

---

<b>WARNING</b>	<b>Warning denotes a hazard. It calls attention to a procedure which, if not correctly performed or adhered to, could result in injury or loss of life. Do not proceed beyond a warning note until the indicated conditions are fully understood and met.</b>
----------------	---

---

---

<b>CAUTION</b>	Caution denotes a hazard. It calls attention to a procedure that, if not correctly performed or adhered to, could result in damage to or destruction of the instrument. Do not proceed beyond a caution sign until the indicated conditions are fully understood and met.
----------------	---

---

---

## Definitions

- *Specifications* describe the performance of parameters covered by the product warranty (temperature –0 to 55 °C, unless otherwise noted.)
- *Typical* describes additional product performance information that is not covered by the product warranty. It is performance beyond specification that 80% of the units exhibit with a 95% confidence level over the temperature range 20 to 30 °C. Typical performance does not include measurement uncertainty.
- *Nominal* values indicate expected performance or describe product performance that is useful in the application of the product, but is not covered by the product warranty.
- *Characteristic Performance* describes performance parameter that the product is expected to meet before it leaves the factory, but is not verified in the field and is not covered by the product warranty. A characteristic includes the same guard bands as a specification.



---

# Contents

## Z5623A Option H01

Description	2
Verifying the Shipment	2
General Specifications	3
Power Requirements	3
Electrical and Environmental Requirements	4
Environmental Tests	4
Equipment Heating and Cooling	4
Required Conditions for Accuracy Enhanced Measurement	6
Dimensions and Space Requirements	6
Front and Rear Panel Features	8
Front Panel	8
Port Connection Status LCD	8
Front Panel Ports	8
Line Power Switch	8
Ground Connector	8
Rear Panel	9
GPIB Connector	9
Address Switch	9
Line Module	9
Power Cables	9
Available Fuses	10
System Setup	11
Setting the Test Set Address Switch	12
Operation	13
Commands	13
Reset Command	15
Switch Count Commands	15
Service Information	16
Functional Tests	16
Equipment Required	16
Insertion Loss	17
Functional Test Record	18
Replaceable Parts	20
Troubleshooting	22
Troubleshooting the Power Supply	22
Troubleshooting the Controller Board	22
Troubleshooting the Switches and Switch Driver Board	23
Theory of Operation	24
System Theory	24
A1 Power Supply Theory	25
A2 Front Panel Display Theory	25
A3 Controller Board Theory	25
Safety and Regulatory Information	26
Introduction	26
Connector Care and Cleaning	26
Declaration of Conformity	26
Statement of Compliance	26
Shipping Instructions	26
General Safety Considerations	27
Safety Earth Ground	27
Before Applying Power	27
Servicing	28

---

# Contents

Electrostatic Discharge Protection .....	29
Regulatory Information.....	30
Instrument Markings.....	30
Lithium Battery Disposal .....	31
Compliance with Canadian EMC Requirements .....	31
Compliance with German FTZ Emissions Requirements .....	31
Compliance with German Noise Requirements .....	31
Contacting Agilent Sales and Service Offices .....	32

---

# **Z5623A Option H01**

---

## Description

The Agilent Technologies Z5623A Option H01 Dynamic Accuracy Test Set is designed for use with Agilent Network Analyzers such as the E8356A/E8357A/E8358A PNA and the 8753 Series Network Analyzers.

The Z5623A H01 can measure a receiver's relative power linearity (dynamic accuracy) when used with an E-Series power meter, a thermocouple power sensor, and a test algorithm. The Z5623A H01 was designed for maximum measurement accuracy over a 120 dB dynamic range. The signal's amplification and attenuation is controlled via internal switches and attenuators.

The Z5623A H01 can only be controlled using an external GPIB controller.

---

**NOTE** Where necessary, part numbers will be provided in parentheses after the description of a part for clarification. Example: “Use two Type-N 50  $\Omega$  jumper cables (8120-6995).”

---



---

## Verifying the Shipment

After the test set has been unpacked, keep the original packaging materials so they can be used if you need to transport the instrument. Inspect the test set and all accessories for any signs of damage that may have occurred during shipment. If your test set or any accessories appear to be damaged or missing refer to [“Contacting Agilent Sales and Service Offices” on page 32](#).

**Table 1 Agilent Z5623A Option H01 Accessories Supplied**

Description	Part Number	Qty
Power Cord	See <a href="#">Figure 1 on page 5</a>	1
Rack Mount Kit	5063-9232	1
Front Handle Kit	5063-9226	1
User's and Service Guide	Z5623-90001	1



---

## General Specifications

Specifications for the Z5623A Option H01 Dynamic Accuracy Test Set is characteristic for the System performance of the PNA and Test Set. Actual performance of the system is based on the customers PNA that is used with the test set.

A functional certificate is supplied for the Z5623A Option H01. The Z5623A Option H01 performance is based on external components such as the calibration kit and network analyzer. There are no internal adjustment in the Z5623A Option H01, therefore an annual calibration is not required.

---

**CAUTION** This product has an autoranging line voltage input. Be sure the supply voltage is within the specified range. If the ac line voltage does not fall within these ranges, an autotransformer that provides third wire continuity to earth ground should be used.

---

## Power Requirements

Verify that the required ac power is available at all necessary locations before installing the Test Set to the PNA.

- Air conditioning equipment (or other motor-operated equipment) should not be placed on the same ac line that powers the Test Set.
- [Table 2](#) contains the maximum wattage for the test set. This table can be use to determine the electrical and cooling requirements.

---

**NOTE** Values are based on 120 Vac supplied to each instrument at 60 Hz.

---

**Table 2 Power Requirements**

Instrument	Maximum Wattage
Z5623AH01	40

---

## Electrical and Environmental Requirements

**Table 3 Z5623A Operating Environment**

<b>Temperature</b>	
Operation	0 °C to 40 °C (32 °F to 104 °F)
Storage	–40 °C to +70 °C (–40 °F to +158 °F)
Measurement Calibration	20 °C to 26 °C (68 °F to 79 °F)
Performance Verification	Temperature must be within 1 °C (1.8 °F) of the temperature at which the measurement calibration was performed.
Pressure Altitude (Operation or Storage)	0 to 4600 meters (~ 15,000 feet)







### Environmental Tests

The Z5623AH01 complies with all applicable safety and regulatory requirements for the intended location of use and have been evaluated to assure that they are consistent with Agilent quality and reliability goals. On the basis of that evaluation, the following environmental tests have been deemed unnecessary and have not been performed: temperature, humidity, shock, vibration, altitude and power line conditions.

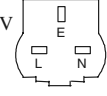
### Equipment Heating and Cooling

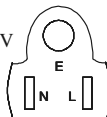
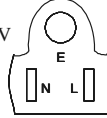
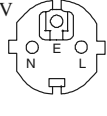
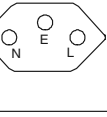
If necessary, install air conditioning and heating to maintain the ambient temperature within the appropriate range. Air conditioning capacity must be consistent with the ratings given in [Table 3](#).

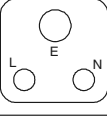
**Figure 1 Power Cable and Line (Mains) Plug Part Numbers**

Plug Type <sup>a</sup>	Cable Part Number	Plug <sup>b</sup> Description	Length cm (in.)	Cable Color	For Use in Country
250V 	8120-8705	Straight BS 1363A	229 (90)	Mint Gray	Option 900 United Kingdom, Hong Kong, Cyprus, Nigeria, Singapore, Zimbabwe
	8120-8709	90°	229 (90)	Mint Gray	
250V 	8120-1369	Straight AS 3112	210 (79)	Gray	Option 901 Argentina, Australia, New Zealand, Mainland China
	8120-0696	90°	200 (78)	Gray	
125V 	8120-1378	Straight NEMA 5-15P	203 (80)	Jade Gray	Option 903 United States, Canada, Brazil, Colombia, Mexico, Philippines, Saudi Arabia, Taiwan
	8120-1521	90°	203 (80)	Jade Gray	
125V 	8120-4753	Straight NEMA 5-15P	229 (90)	Gray	Option 918 Japan
	8120-4754	90°	229 (90)	Gray	
250V 	8120-1689	Straight CEE 7/VII	200 (78)	Mint Gray	Option 902 Continental Europe, Central African Republic, United Arab Republic
	8120-1692	90°	200 (78)	Mint Gray	
230V 	8120-2104	Straight SEV Type 12	200 (78)	Gray	Option 906 Switzerland
	8120-2296	90°	200 (78)	Gray	
220V 	8120-2956	Straight SR 107-2-D	200 (78)	Gray	Option 912 Denmark
	8120-2957	90°	200 (78)	Gray	
250V 	8120-4211	Straight IEC 83-B1	200 (78)	Mint Gray	Option 917 South Africa, India
	8120-4600	90°	200 (78)	Mint Gray	
250V 	8120-5182	Straight SI 32	200 (78)	Jade Gray	Option 919 Israel
	8120-5181	90°	200 (78)	Jade Gray	

a. E = earth ground, L = line, and N = neutral.  
b. Plug identifier numbers describe the plug only. The Agilent Technologies part number is for the complete cable assembly.

## Required Conditions for Accuracy Enhanced Measurement

Accuracy-enhanced (error-corrected) measurements require the ambient temperature of the PNA and Test Set to be maintained within  $\pm 1$  °C of the ambient temperature at calibration.

**Table 4 Performance Characteristics**

Parameter	Typical
Frequency Range	1.2 GHz
Insertion Loss <sup>1</sup>	
Source to Power Meter Port	-7.5 dB ( $\pm$ 3dB)
Source to Power Meter Port with Amplifier	+9.0 dB ( $\pm$ 4dB)
Source to Receiver Port	-7 dB ( $\pm$ 3 dB)
Power Meter Port to Source (Amplifier IN selected)	$\leq$ -45 dB
Input Power Damage Level	>1 watt (RF + DC)

1. Attenuator A = 0 dB, Attenuator B = 0 dB, Amplifier OUT

## Dimensions and Space Requirements

Standard installation of the Z5623A Option H01 and PNA includes configuration and installation on a customer provided lab bench or table top of adequate size and strength.

**Table 5 System Dimensions**

Item	Weight
Required Bench Top Dimension:	
Clearance above the bench	89 cm (3.5 in)
Width	425 cm (16.75 in)
Depth	500 cm (19.7 in)
Weight	9 kg (19.85 lb)

---

**CAUTION** Ventilation Requirements: When installing the instrument in a cabinet, the convection into and out of the instrument must not be restricted. The ambient temperature (outside the cabinet) must be less than the maximum operating temperature of the instrument by 4 °C for every 100 watts dissipated in the cabinet. If the total power dissipated in the cabinet is greater than 800 watts, forced convection must be used.

---

**Figure 2** Ventilation Clearance Requirements

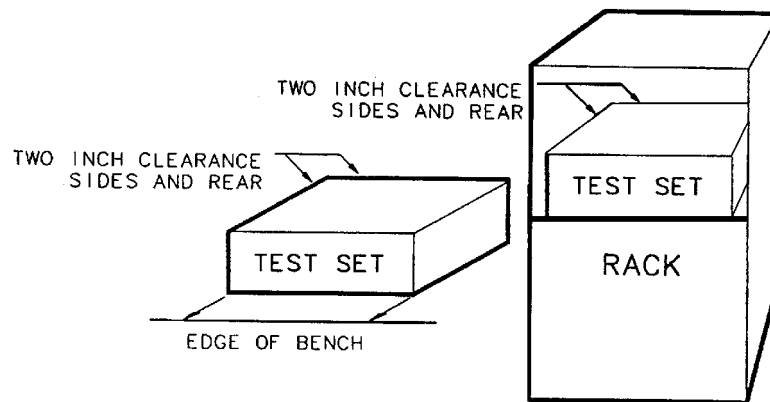

---

## Front and Rear Panel Features

---

**CAUTION** Refer to the standard instrument documentation for damage limits to the ports. Verify that your test setup will not cause those limits to be exceeded.

---

### Front Panel

**Figure 3 Front Panel**

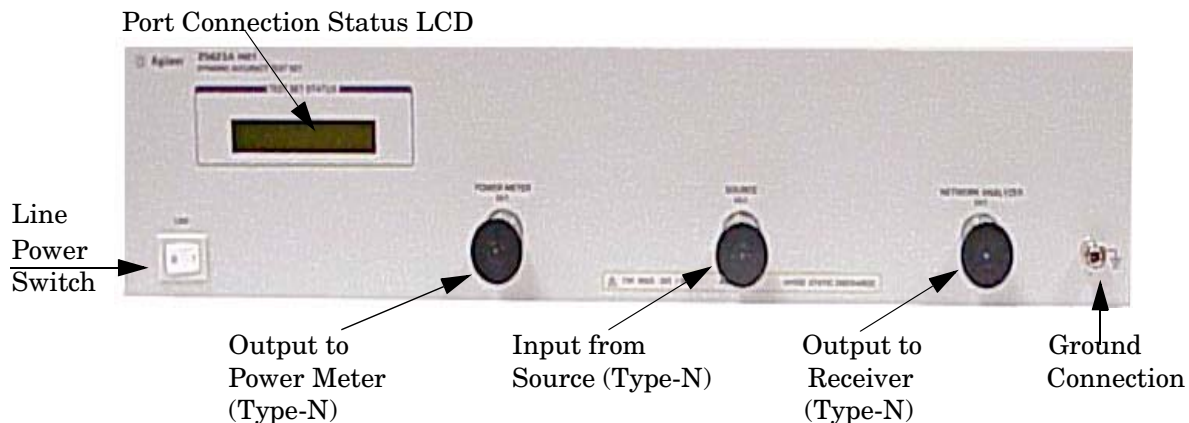

### Port Connection Status LCD

The port connection status LCD provides visual feedback of the settings of the attenuator and the status of the amplifier.

### Front Panel Ports

The OUTPUT to POWER METER, INPUT from SOURCE, and the OUTPUT to RECEIVER ports are 50  $\Omega$  Type-N connectors.

**CAUTION** Do not input more than 1 watt (RF and DC combined) to the source port, damage to the internal RF switches or the analyzer may occur.

---

### Line Power Switch

The line switch disconnects the mains circuits from the mains supply after the EMI filters and before other parts of the instrument.

-  – Standby
- 1** – ON (Power LED On)

### Ground Connector

The ground connector provides a convenient front panel ground connection for a standard banana plug.

## Rear Panel

Figure 4 Rear Panel

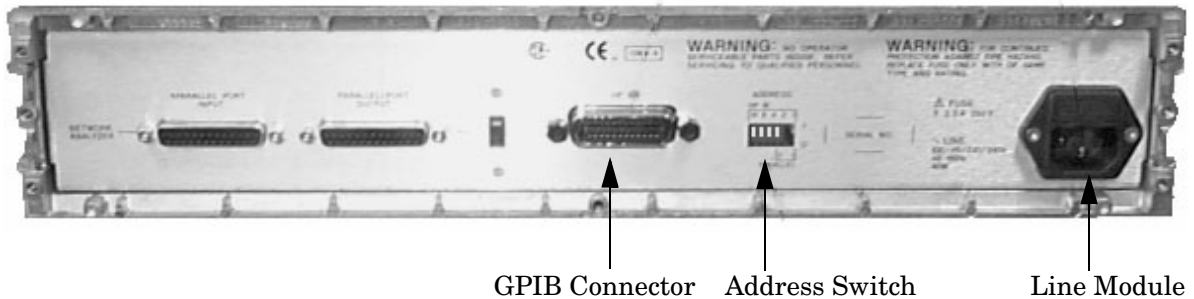

### GPIB Connector

This connector allows the test set to be connected directly to a controller.

### Address Switch

The address switch sets the GPIB address of the test set. See [“Setting the Test Set Address Switch” on page 12](#) for information.

### Line Module

The line module contains the power cable receptacle and the line fuse. The line module is an autoranging input and is designed to be used with an ac power source with a nominal voltage of either 115 V or 230 V.

### Power Cables

The line power cable is supplied in one of several configurations, depending on the destination of the original shipment.

Each instrument is equipped with a three-wire power cable. When connected to an appropriate ac power receptacle, this cable grounds the instrument chassis. The type of power cable shipped with each instrument is dependent on the country of destination. See [Figure 1 on page 5](#) for the part numbers of these power cables. Cables are available in different lengths. Refer to [“Contacting Agilent Sales and Service Offices” on page 32](#) for descriptions and part numbers of cables other than those described in [Figure 1](#).

---

**CAUTION** Always use the three-prong ac power cord supplied with this product. Failure to ensure adequate grounding by not using this cord may cause damage to the product.

---



---

**WARNING** **This is a Safety Class I product (provided with a protective earthing ground incorporated in the power cord). The mains plug shall only be inserted into a socket outlet provided with a protective earth contact. Any interruption of the protective conductor, inside or outside the instrument, is likely to make the instrument dangerous. Intentional interruption of the protective cover is prohibited.**

---

### Available Fuses

- **United States (115 V orientation)**  
Fuse (F 3 A/250V, 2110-0780) U.L. listed and CSA certified
- **Europe (230 V orientation)**  
Fuse (F 3.15A/250V, 2110-0655) IEC listed and U.L. recognized certified

---

**WARNING** For continued protection against fire hazard replace line fuse only with same type and rating:

- **United States—F 3A/250V, Part Number 2110-0780**
- **Europe—F 3.15A/250V, Part Number 2110-0655**

The use of other fuses or material is prohibited.

---

**Figure 5** Line Fuse



---

**CAUTION** This instrument has autoranging line voltage input; be sure the supply voltage is within the specified range.

---



## System Setup

The Z5623A Option H01 Test Set is designed to be placed near the network analyzer on a bench top and connected as shown in [Figure 6](#).

1. Connect a GPIB cable from the controller to the rear panel of the network analyzer. See [“Operation” on page 13](#).
2. After the proper front and rear panel connections have been made, turn on the test set using the front panel line switch. The front panel line switch disconnects the mains circuits from the mains supply after the EMI filters and before other parts of the instrument.

**NOTE** For accurate repeatable measurements, be sure to let the test set warm up for at least two hours. For the most stable and accurate measurements, leave the test set turned on at all times. Do not touch the power sensor for at least 30 minutes before making measurements.

**Figure 6** Connecting the Test Set to the Network Analyzer

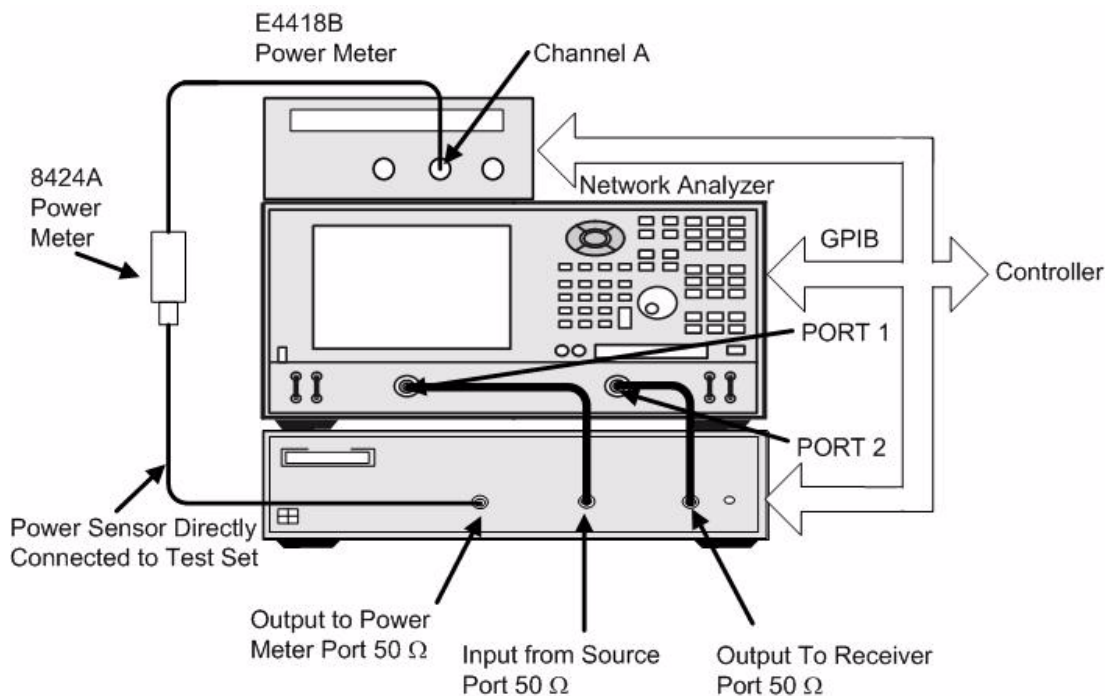

## Setting the Test Set Address Switch

The test set is shipped with the GPIB address set to 12, as shown in [Figure 7](#).

To set the GPIB address, set all five switches so that the sum of the switches in the “ON” (or 1) position equals the desired address. In the example below, the two switches in the “ON” position are 8 and 4, thus the GPIB address equals 12.

**Figure 7** The Test Set Address Switch

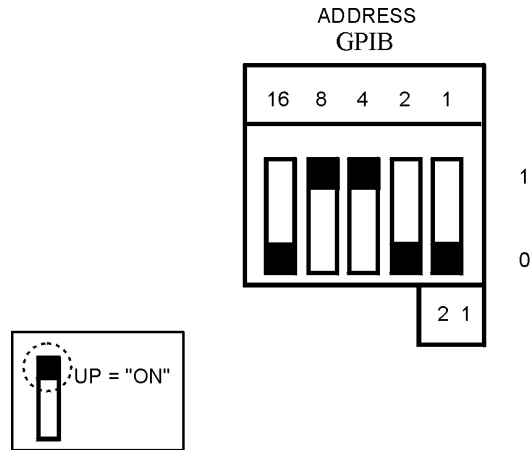

## Operation

The Z5623A Option H01 is a “slave” instrument: a controller must be used to control the test set. The controller can control the test set using GPIB commands via the GPIB connector.

## Commands

The only way to control the test set is to address the Option H01 test set directly over GPIB using a controller to write directly to the test set's GPIB port. The following example assumes that the address of the test set is 12.

```
OUTPUT 712;"command$"
```

If using Quick Basic or Visual Basic, be sure to disable EOI and EOL before sending commands to the test set. Including the semicolon will not ensure that these commands are disabled as would be the case in HP Basic/RMB. Using the Agilent 82335 GPIB Interface and Visual Basic, the following commands will disable the EOI and EOL, send the necessary data to the test set, and re-enable EOI and EOL. Be sure to re-enable the EOI and EOL before sending data to another instrument.

```
HpibEoi(hHpib;7,0) 'disable EOI  
HpibEol(hHpib;7,"",0) 'disable EOL  
HpibOutput(hHpib;712,chr$([D])) 'send command to test set  
HpibEol(hHpib;7,chr$(13)+chr$(10),2) 're-enable EOL and set  
to'chr$(13)+chr$(10)  
HpibEoi(hHpib;7,1,) 're-enable EOI
```

where hHpib specifies the handle returned by HpibOpen.

For more information on the EOI and EOL commands, refer to the programming library manual supplied with the Agilent 82335 interface.

**Figure 8 Controlling the Test Set Over the GPIB**

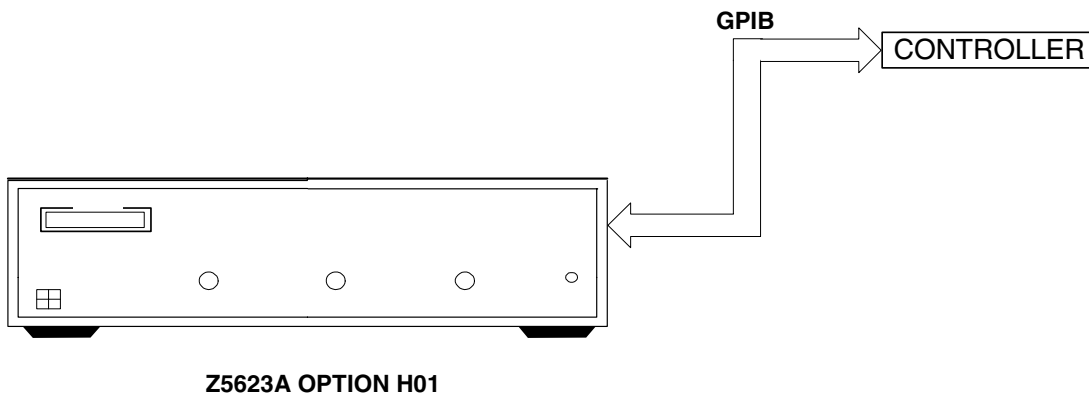

**Table 6 Test Port Addresses**

<b>Connection Path</b>	<b>GPIB Command</b>
Attenuator A = 0 dB	at_a = 0
Attenuator A = 1 dB	at_a = 1
Attenuator A = 2 dB	at_a = 2
Attenuator A = 3 dB	at_a = 3
Attenuator A = 4 dB	at_a = 4
Attenuator A = 5 dB	at_a = 5
Attenuator A = 6 dB	at_a = 6
Attenuator A = 7 dB	at_a = 7
Attenuator A = 8 dB	at_a = 8
Attenuator A = 9 dB	at_a = 9
Attenuator A = 10 dB	at_a = 10
Attenuator A = 11 dB	at_a = 11
Attenuator B = 0 dB	at_b = 0
Attenuator B = 10 dB	at_b = 10
Attenuator B = 20 dB	at_b = 20
Attenuator B = 30 dB	at_b = 30
Attenuator B = 40 dB	at_b = 40
Attenuator B = 50 dB	at_b = 50
Attenuator B = 60 dB	at_b = 60
Attenuator B = 70 dB	at_b = 70
Attenuator B = 80 dB	at_b = 80
Attenuator B = 90 dB	at_b = 90
Attenuator B = 100 dB	at_b = 100
Attenuator B = 110 dB	at_b = 110
Amplifier IN	amp_in
Amplifier OUT	amp_out
Reset Attenuators 0dB, Amplifier OUT	*rst
Test Set Identification	idn? (no response over GPIB)
Test Set Serial Number	sn?

To identify the test set serial number, send the following commands:

```
OUTPUT 712;"sn?"
ENTER 712;Sn$
DISP Sn$
```

---

**NOTE** The "idn?" command displays the instrument IP on the front panel, it does not respond over the GPIB.

---

### Reset Command

When the Reset command is sent, the test set is set to the default state where the attenuators are set to 0 dB and the amplifier is switched out. (The test set is in the default state at power on.)

### Switch Count Commands

Refer to the Option H01 block diagram, [Figure 9 on page 23](#), for the switch paths.

To read the individual switch count, send the following command:

```
Output 712;"sw53?"
```

The above example shows the command for switch 53 only. This command returns a value that indicates the number of times the particular switch has been addressed and switched. To enter additional commands, refer to [Table 7](#).

**Table 7** Switch Count Commands

Switch Number	GPIB Command
SW53	sw53?
SW54	sw54?
SW55	sw55?
SW56	sw56?
SW57	sw57?
SW74	sw74?
SW75	sw75?
SW76	sw76?
SW77	sw77?

---

**NOTE** Although the attenuator specification for switching and settling time is 20 milliseconds, it is recommended that test software that utilizes this test set allow 100 milliseconds.

---

---

## Service Information

### Functional Tests

Functional testing consists of measuring insertion loss, return loss, and isolation between all ports. For the most accurate measurements, the use of an Agilent E835xA 50  $\Omega$  network analyzer is recommended and its use is assumed in these notes. Familiarity with RF/microwave measurements is also assumed. The use of adapters may be required and their effects should be accounted within the measurements.

Prior to June, 2007 the Z5623A Option H01 had hard specifications, therefore a calibration certificate was available for the test set. The specifications have now been replaced with typical performance characteristics. This change was made because performance specification from the Z5623A H01 are not critical to the network analyzer dynamic accuracy test. The “accuracy” of the test set does not affect the accuracy of the dynamic accuracy test result. Therefore, only a functional test certificate is offered for the Z523A H01 Test Set.

---

**NOTE**        The “[Functional Test Record](#)” on [page 18](#) may be duplicated to record the results of the functional tests.

---

### Equipment Required

- Agilent E835xA PNA Series Network Analyzer (or equivalent)
- Test Port Extension Cables and Adapters
- 85032B Calibration Kit (50  $\Omega$ , Type-N or equivalent)

There are no adjustments required for the Agilent Z5623A Option H01 test set.

Set up the network analyzer with the following:

1. Center Frequency = 1.2 GHz
2. Frequency Span = 1.0 GHz

Perform a full two-port calibration at the ends of two cables attached to the two test ports of the network analyzer. (Use a Type-N female-to-female adaptor for the transmission calibration).

## Insertion Loss

1. Connect the cable attached to PORT 1 of the network analyzer to the “INPUT FROM SOURCE” port of the test set.
2. Connect the cable from PORT 2 of the network analyzer to the “OUTPUT TO POWER METER” port of the test set.
3. Set up the test set with the attenuators at 0 dB and the amplifier switched out. Execute the following command over GPIB:

```
output712;“*rst;”
```

For complete information on controlling the test set, refer to “[Operation](#)” on page 13.

4. Set up the network analyzer to measure S21, Source to Power Meter.
5. Measure the amplitude at 1.2 GHz and record the value in [Table 8](#).
6. Measure the amplitude at 1.1 GHz and record the value.
7. Measure the amplitude at 1.3 GHz and record the value.
8. Set up the test set with the amplifier switched in. Execute the following command over GPIB:

```
output 712;“amp_in;”
```

9. Measure the amplitude at 1.2 GHz and record the value.
10. Set up the network analyzer to measure S12, Power Meter to Source.
11. Measure the amplitude at 1.2 GHz and record the value.
12. Connect PORT 2 of the network analyzer to the “OUTPUT TO RECEIVER” port.
13. Set up the network analyzer to measure S21, Source to Receiver. See [Figure 9 on page 23](#).
14. Set up the test set with the amplifier switched out. Execute the following command over GPIB:

```
output 712;“amp_out;”
```

15. Measure the amplitude at 1.2 GHz and record the value in [Table 9 on page 20](#).
16. Step through all of the 11 dB attenuator steps and 110 dB attenuator steps using the commands listed in [Table 7 on page 15](#). Verify that all steps are functioning correctly.

### Functional Test Record

The following pages are designed to be duplicated and used as a template for the performance tests.

Test Facility_____	Report Number_____		
_____	Date_____		
_____	Date of Last System Calibration_____		
Tested by_____	Customer_____		
Model_____	Serial Number_____		
Ambient Temperature_____ °C	Relative Humidity_____ %		
Test Equipment Used	Model Number	Trace Number	Cal Due Date
_____	_____	_____	_____
_____	_____	_____	_____
_____	_____	_____	_____
_____	_____	_____	_____
_____	_____	_____	_____
Special Notes:_____			
_____			
_____			
_____			



**Table 8 Z5623A Option H01 Insertion Loss Test Record**

<b>Test Description</b>	<b>Port</b>	<b>Typical</b>	<b>Measured Results</b>
<b>Insertion Loss w/o amplifier</b>  1.2 GHz 1.1 GHz 1.3 GHz	INPUT FROM SOURCE Port to OUTPUT TO POWER METER Port	-7.5 ( $\pm 3$ dB) $\leq -17$ dB $\leq -17$ dB	_____ _____ _____
<b>Insertion Loss w/ amplifier</b>  1.2 GHz	INPUT FROM SOURCE Port to OUTPUT TO POWER METER Port	+9.0 ( $\pm 4$ dB)	_____
<b>Insertion Loss w/ amplifier</b>  1.2 GHz	OUTPUT TO POWER METER Port to INPUT FROM SOURCE Port	$\leq 45$ dB	_____
<b>Insertion Loss w/o amplifier</b>  1.2 GHz	INPUT FROM SOURCE Port to OUTPUT TO RECEIVER Port	-7.0 ( $\pm 3$ dB)	_____

## Replaceable Parts

The following table contains the list of replaceable parts for the Agilent Z5623A Option H01 Dynamic Accuracy Test Set. If any of these parts or assemblies are replaced, you must run all performance tests to verify conformance to specifications.

---

**NOTE** Special options are built to order, long lead times may be encountered when ordering replacement parts.

---

**Table 9**      **Replaceable Parts**

Replacement Part	Part Number	Qty
Isolator 1.19-1.21 GHz	0955-1322	1
Amplifier .02-4.0 GHz	0955-1323	1
Filter BP 1.2 GHz	0955-1324	1
Power Supply, 110 W	0950-2252	1
Adapter SMA (m)-SMA (m)	1250-1159	2
Feet, spring	1460-1345	2
Termination, 50 $\Omega$	1810-0118	1
Fuse, daughter board	2110-0518	1
Fuse, 3A 250V (f), ac line module	2110-0780	2
Cover, top	5002-1047	1
Cover, bottom	5002-1088	1
Cover, side w/o handle	5002-3936	1
Cover, side	5002-3913	1
Shield, power supply	5002-4017	1
Frame, rear	5021-5802	1
Strut, side	5021-5887	2
Frame, front	5022-1187	1
Foot	5041-9167	4
Trim, front frame side	5041-9170	2
Trim, top	5041-9176	1
Front Cap, strap handle	5041-9186	1
Rear Cap, strap handle	5041-9187	1
Standoff, rear panel	5041-9188	4
Handle, strap	5063-9210	1
Front Handle Kit	5063-9226	1
Rack Mount Kit	5063-9232	1
Splitter	5086-7408	1
LCD Display Cable	8120-8794	1
Assembly, switch	08711-60129	1
Deck RF	Z5623-00002	1
Bracket Attenuator	Z5623-00003	2
RF Cable PM PRT/FLTR	Z5623-20001	1

**Table 9 Replaceable Parts (Continued)**

Replacement Part	Part Number	Qty
RF Cable 11667/FLR	Z5623-20002	1
RF Cable SCR PT/IR	Z5623-20003	1
RF Cable IR OUT/SW	Z5623-20004	1
RF Cable SW-2/8494	Z5623-20005	1
RF Cable NA PT8496	Z5623-20006	1
RF Cable WS-4/A IN	Z5623-20007	1
RF Cable SW-1/AMOUT	Z5623-20008	1
Attenuator Programmable 11 dB	33320-60005	1
Attenuator Programmable 110 dB	33322-60010	1
Deck	87050-00004	1
Wire Harness, 04c, 0.3m, 13f-06f	87050-60021	1
Wire Harness, 04c, 0.13m, 04f-04f	87050-60022	1
Wire Harness, 40c, 0.09m, 40f-40f	87050-60023	2
Fan Assembly 5 cfm	87050-60027	1
Daughter Control Board	87050-60324	1
Front Panel Subassembly <sup>1</sup>	Z5623-60001	1
Controller Mother Board <sup>1</sup>	Z5623-60002	1
Cable Assembly AMP #H01	Z5623-60003	1
Cable Assembly ATTN #H01	Z5623-60005	2
User's and Service Guide <sup>1</sup>	Z5623-90001	1
Rear Panel	87075-00003	1
Bracket, fan	87075-00005	1
Cable Assembly, ac line	87130-60007	1
Switch, Transfer	87222-60001	1
Power Cord	See <a href="#">Figure 1</a>	1

1. To order replacement parts, please contact the Agilent Technologies Component Test PGU at (707) 577-6802 with the part number, module/model number and option number. If ordering parts through your local Agilent Technologies sales or service office, specify that they are ordered through the Agilent Support Group.

---

**NOTE** Before replacing an assembly or board, inspect the assembly for obvious, easily repaired defects such as bent pins on ICs or cold solder joints.

---

## Troubleshooting

This section contains information on troubleshooting the test set to the assembly level only. By following these procedures, you may determine if the power supply, front panel, or main switch board needs replacing. Refer to [Figure 9, “Z5623A Option H01 Block Diagram,”](#) as an aid in troubleshooting.

The theory of operation information can be found beginning on [Page 24](#).

---

**WARNING**     **Always turn the instrument power off before removing or installing an assembly.**

---

**NOTE**         If you need to disassemble the instrument, be sure to work at an antistatic workstation and use a grounded wrist strap to prevent damage from electrostatic discharge (ESD). See [Figure 10 on page 29](#).

---

### Troubleshooting the Power Supply

Turn the instrument on. Verify the condition of the LCD on the front panel:

1. If the LCD is off, check the main fuse located in the line module at the rear of the instrument. Refer to [Figure 5 on page 10](#).
2. If the fuse is in working order and the LCD is still off, check the cable and connections between the main board and front panel board.
3. If the cable and connections are working and the LCD is still off, there is still a possibility that the power supply is not supplying the necessary +24 V, +12 V, and +5 V to the main board.

Disconnect the dc power cable from the power supply to the main switch board and measure the voltages. They should be +24 V, +12 V, and +5 V. If not, replace the power supply.

### Troubleshooting the Controller Board

Turn the instrument power on and verify the following:

1. Check the LCD display for the model/option and revision information; if there is no backlite or horizontal/vertical lines are missing, verify that the power supply is working properly, if so replace the LCD display.
2. If there is no information or the information is scrambled, replace the controller board.
3. Verify the switching paths by issuing commands to switch each of the paths. Ensure that the LCD indicates the appropriate path.

## Troubleshooting the Switches and Switch Driver Board

Turn the instrument power on. Verify the condition of each of the switching paths by issuing commands to switch each of the paths. Verify each of the RF paths connections. If an RF path is not connected to the necessary port or terminated in 50  $\Omega$ . Check for proper bias voltages on the switch. If the voltages are correct replace the switch. If the voltages are not correct, replace the switch driver (daughter) board.

Refer to [Figure 9](#) for a block diagram of the major components and the switching paths of the Agilent Z5623A Option H01.

**Figure 9 Z5623A Option H01 Block Diagram**

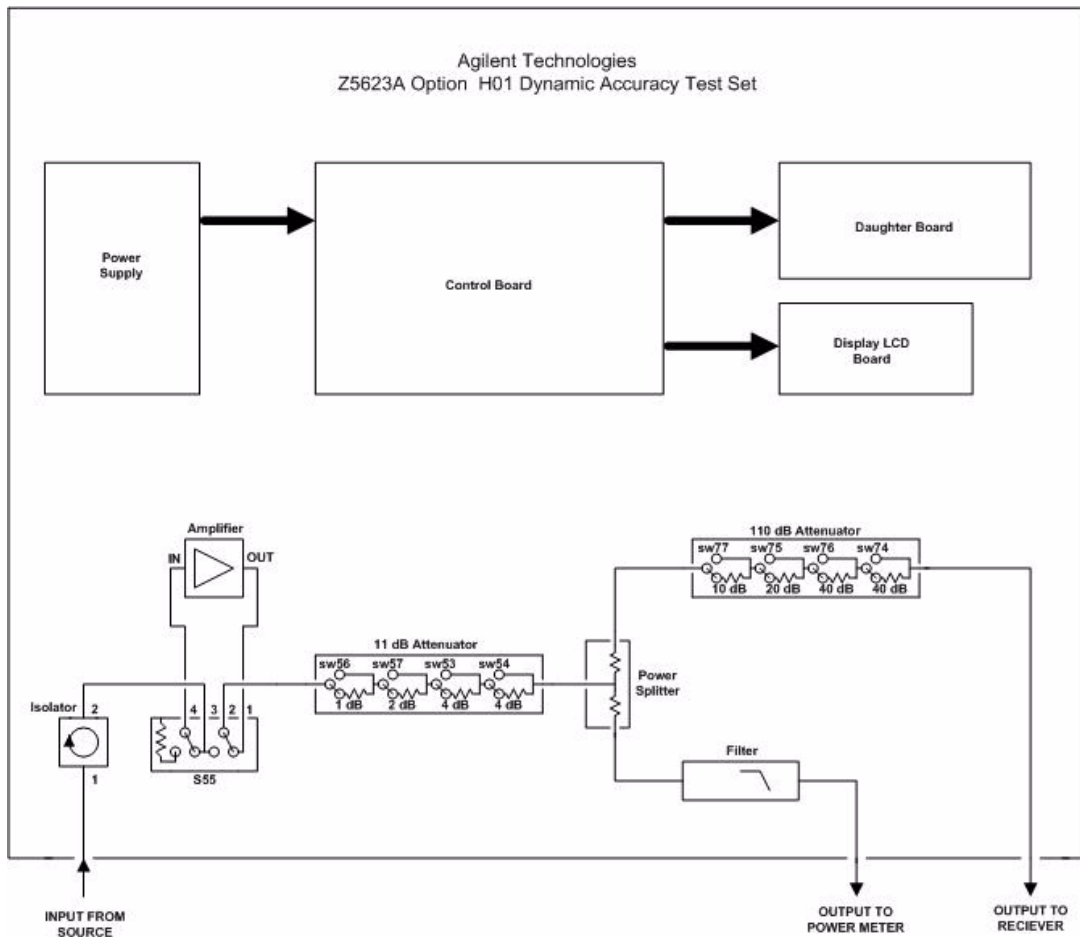

## Theory of Operation

The theory of operation begins with a general description of the Agilent Z5623A Option H01 Dynamic Accuracy Test Set. This is followed by more detailed operating theory. The operation of each group is described briefly, to the assembly level only. Detailed component level circuit theory is not provided.

### System Theory

The test set consists of three main components: a power supply, a front panel display, and a controller interface mother board. The purpose of the power supply is to provide power to both the front panel display and the main switch board. The front panel display serves to indicate the switching paths to the user. Finally, the controller interface mother board does the actual switching between the different ports.

The Z5623A Option H01 Dynamic Accuracy Test Set is used to measure the dynamic accuracy of a network analyzer's receiver. [Figure 10](#) shows a simplified block diagram of the test set.

**Figure 10** Simplified Block Diagram

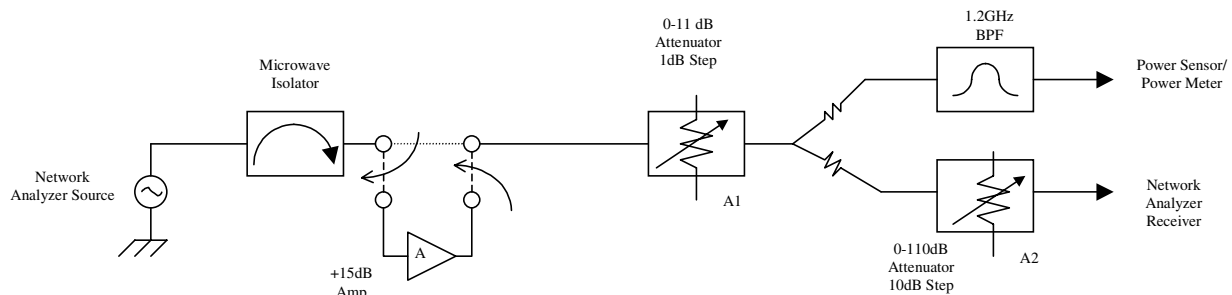

The Z5623A Option H01 was designed to allow a power meter to be used as the linearity reference. The power splitter and attenuators A1 and A2 are used in conjunction to vary the power to the receiver by 120 dB while the power delivered to the power meter stays within a 10 dB range.

Attenuators A1 and A2 work as follows: assume the source is set to approximately +7 dBm (to account for the insertion loss through the signal path). With the source power set, the power meter measures 0 dBm.

As the dynamic accuracy test progresses, A1 is stepped from 0 to 10 dB. When the 1 dB step attenuator (A1) reaches 10 dB, the power meter is at -10 dBm which is at the limit predefined for the sensor. At this point, attenuator A2 is increased by 10 dB and A1 is decreased 10 dB (set back to 0). The power meter again reads 0 dBm while the power delivered to the network analyzer remains the same. This progression is repeated until A2 is set to maximum attenuation of 110 dB.

It is necessary to eliminate the step size error and the mismatch error between the receiver and the test set whenever A2 switches. This is done using an attenuator correction measurement embedded into the measurement algorithm. The source power of the network analyzer is adjusted until the receiver reads the same power before and after the attenuators are changed. The difference in source power is recorded and used within the measurement algorithm.

---

**NOTE** The power sensor used by the power meter must be a thermocouple type sensor. The linearity uncertainty error associated with the thermocouple power sensors is much lower than the uncertainty error of the diode based power sensors.

---

**CAUTION** It is mandatory to leave the power sensor untouched for a minimum of 30 minutes to allow the sensor to stabilize. This test is sensitive to heating of the power sensor caused by handling.

---

## A1 Power Supply Theory

The switching power supply provides regulated dc voltages to power all assemblies in the test set. A dc cable provides power to the main switch board. A connector from the main switch board to the front panel display provides dc power and control signals to the front panel. The power supply provides the following supplies: +24 V, +12 V, and +5 V.

## A2 Front Panel Display Theory

The front panel display consists of an LCD. The LCD is divided into two lines. The top line indicates the attenuator settings. The bottom line indicates the status of the amplifier. Control signals and dc power are provided by a cable connected to the controller board.

## A3 Controller Board Theory

The controller and daughter boards provide the bias for the switching paths. Refer to the block diagram, [Figure 9 on page 23](#).

---

## Safety and Regulatory Information

### Introduction

Review this product and related documentation to familiarize yourself with safety markings and instructions before you operate the instrument. The documentation contains information and warnings that must be followed by the user to ensure safe operation and to maintain the product in a safe condition.

### Connector Care and Cleaning

If alcohol is used to clean the connectors, the power cord to the instrument must be removed. All cleaning should take place in a well ventilated area. Allow adequate time for the fumes to disperse and moist alcohol to evaporate prior to energizing the instrument.

---

**WARNING**     **To prevent electrical shock, disconnect the Agilent Technologies model product from mains before cleaning. Use a dry cloth or one slightly dampened with water to clean the external case parts. Do not attempt to clean internally.**

---

### Declaration of Conformity

For a copy of the manufacturer's Declaration of Conformity for this apparatus, contact your local Agilent Technologies office or sales representative. Refer to [“Contacting Agilent Sales and Service Offices” on page 32](#).

### Statement of Compliance

This instrument has been designed and tested in accordance with IEC Publication 1010, Safety Requirements for Electronic Measuring Apparatus, and has been supplied in a safe condition. The instruction documentation contains information and warnings which must be followed by the user to ensure safe operation and to maintain the instrument in a safe condition.

### Shipping Instructions

You must always call the Agilent Technologies Instrument Support Center to initiate service before retuning your instrument to a service office. See [“Contacting Agilent Sales and Service Offices” on page 32](#). Always transport or ship the instrument using the original packaging if possible. If not, comparable packaging must be used. Attach a complete description of the failure symptoms.



## General Safety Considerations

### Safety Earth Ground

---

**WARNING** This is a Safety Class I product (provided with a protective earthing ground incorporated in the power cord). The mains plug shall only be inserted in a socket outlet provided with a protective earth contact. Any interruption of the protective conductor, inside or outside of the instrument, will make the instrument dangerous. Intentional interruption is prohibited.

---

### Before Applying Power

Verify that the product is configured to match the available main power source. If this product is to be powered by autotransformer, make sure the common terminal is connected to the neutral (grounded) side of the ac power supply.

Cautions applicable to this instrument.

---

**CAUTION** Always use the three-prong ac power cord supplied with this instrument. Failure to ensure adequate earth grounding (by not using this cord) can cause instrument damage.

---

---

**CAUTION** This product is designed for use in Installation Category II and Pollution Degree 2 per IEC 61010 Second Edition and 664 respectively.

---

---

**CAUTION** This instrument has autoranging line voltage input; be sure the supply voltage is within the specified range.

---

---

**CAUTION** Ventilation Requirements: When installing the instrument in a cabinet, the convection into and out of the instrument must not be restricted. The ambient temperature (outside the cabinet) must be less than the maximum operating temperature of the instrument by 4 °C for every 100 watts dissipated in the cabinet. If the total power dissipated in the cabinet is greater than 800 watts, forced convection must be used.

---

## Servicing

Warnings applicable to this instrument.

---

**WARNING** To prevent electrical shock, disconnect the **Agilent Technologies Z5623A Option H01** from the mains before cleaning. Use a dry cloth or one slightly dampened with water to clean the external case parts. Do not attempt to clean internally.

---

---

**WARNING** For continued protection against fire hazard replace line fuse only with same type and rating:

- United States—F 3.0A/250V, Part Number 2110-0780
- Europe—F 3.15A/250V, Part Number 2110-0655

The use of other fuses or material is prohibited.

---

---

**WARNING** This is a Safety Class I product (provided with a protective earthing ground incorporated in the power cord). The mains plug shall be inserted only into a socket outlet provided with a protective earth contact. Any interruption of the protective conductor, inside or outside the product is likely to make the product dangerous. Intentional interruption is prohibited.

---

---

**WARNING** These servicing instructions are for use by qualified personnel only.

---

---

**WARNING** The opening of covers or removal of parts is likely to expose dangerous voltages. Disconnect the instrument from all voltage sources while it is being opened.

---

---

**WARNING** This product is designed for use in Installation Category II and Pollution Degree 2 per IEC 61010-1: 2001.

---

---

**WARNING** No operator serviceable parts inside. Refer servicing to qualified personnel.

---

---

**WARNING** If this product is not used as specified, the protection provided by the equipment could be impaired. This product must be used in a normal condition (in which all means for protection are intact) only.

---

## Electrostatic Discharge Protection

Protection against electrostatic discharge (ESD) is essential while removing assemblies from or connecting cables to the network analyzer. Static electricity can build up on your body and can easily damage sensitive internal circuit elements when discharged. Static discharges too small to be felt can cause permanent damage. To prevent damage to the instrument:

- *always* have a grounded, conductive table mat (9300-0797) in front of your test equipment.
- *always* wear a grounded wrist strap (9300-1367) with grounding cord (9300-0980), connected to a grounded conductive table mat, having a 1 M $\Omega$  resistor in series with it, when handling components and assemblies or when making connections.
- *always* wear a heel strap (9300-1126) when working in an area with a conductive floor. If you are uncertain about the conductivity of your floor, wear a heel strap.
- *always* ground yourself before you clean, inspect, or make a connection to a static-sensitive device or test port. You can, for example, grasp the grounded outer shell of the test port or cable connector briefly.
- *always* ground the center conductor of a test cable before making a connection to the analyzer test port or other static-sensitive device. This can be done as follows:
  1. Connect a short (from your calibration kit) to one end of the cable to short the center conductor to the outer conductor.
  2. While wearing a grounded wrist strap, grasp the outer shell of the cable connector.
  3. Connect the other end of the cable to the test port and remove the short from the cable.





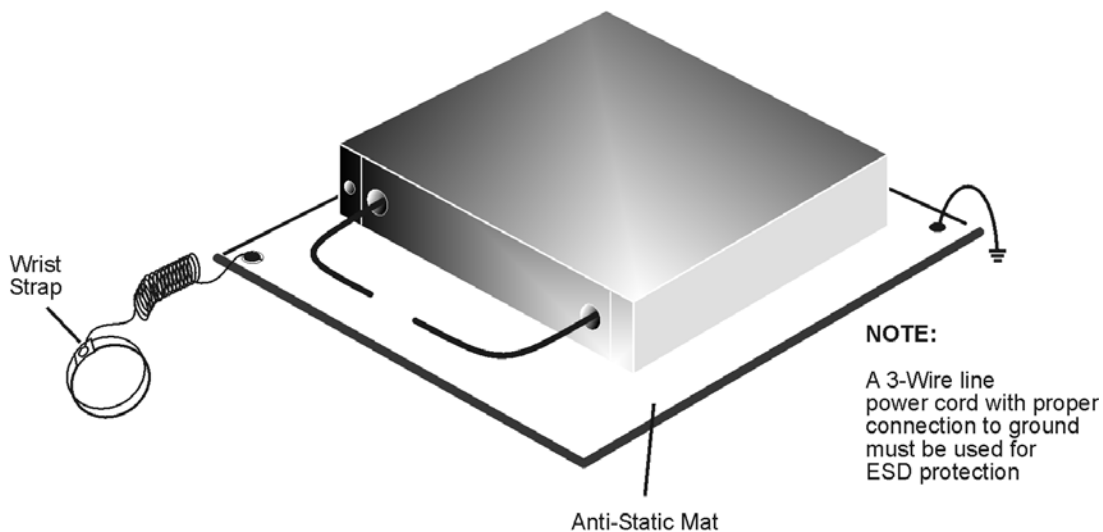







Figure 10 shows a typical ESD protection setup using a grounded mat and wrist strap.

**Figure 10 ESD Protection Setup**



## Regulatory Information

### Instrument Markings

	When you see this symbol on your instrument, you should refer to the instrument's instruction manual for important information.
	This symbol indicates hazardous voltages.
	This symbol indicates that the instrument requires alternating current (ac) input.
	This symbol indicates separate collection for electrical and electronic equipment, mandated under EU law as of August 13, 2005. All electric and electronic equipment are required to be separated from normal waste for disposal (Reference WEEE Directive, 2002/96/EC).
	This symbol indicates that the power line switch is ON.
	This symbol indicates that the power line switch is OFF or in STANDBY position.
	Safety Earth Ground. This is a Safety Class I product (provided with a protective earthing terminal). An uninterruptible safety earth ground must be provided from the main power source to the product input wiring terminals, power cord, or supplied power cord set. Whenever it is likely that the protection has been impaired, the product must be made inoperative and secured against any unintended operation.
	The CE mark is a registered trademark of the European Community. (If accompanied by a year, it is when the design was proven.)
	The CSA mark is a registered trademark of the Canadian Standards Association.
	This is a marking to indicate product compliance with the Canadian Interference-Causing Equipment Standard (ICES-001).
	This is a symbol of an Industrial Scientific and Medical Group 1 Class A product.
	This is a required mark signifying compliance with an EMC requirement. The C-Tick mark is a registered trademark of the Australian Spectrum Management Agency.

## Lithium Battery Disposal

If the battery on the A15 CPU board assembly needs to be disposed of, dispose of it in accordance with your country's requirements. If required, you may return the battery to Agilent Technologies for disposal. Refer to [“Contacting Agilent Sales and Service Offices” on page 32](#) for assistance.

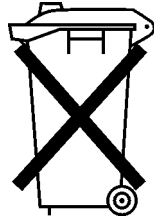

DO NOT THROW BATTERIES AWAY BUT  
COLLECT AS SMALL CHEMICAL WASTE.

## Compliance with Canadian EMC Requirements

This ISM device complies with Canadian ICES-001.  
Cet appareil ISM est conforme a la norme NMB du Canada.

## Compliance with German FTZ Emissions Requirements

This product complies with the German FTZ 526/527 Radiated Emissions and Conducted Emission requirements.

## Compliance with German Noise Requirements

This is to declare that this instrument is in conformance with the German Regulation on Noise Declaration for Machines (Laermangabe nach der Maschinenlaermrerordnung-3. GSGV Deutschland).

Acoustic Noise Emission/Geraeuschemission	
LpA<70 dB	Lpa<70 dB
Operator Position	am Arbeitsplatz
Normal Operation	normaler Betrieb
per ISO 7779	nach DIN 45635 t. 19

---

## Contacting Agilent Sales and Service Offices

Assistance with test and measurement needs, and information on finding a local Agilent office are available on the Internet at:

*<http://www.agilent.com/find/assist>*

You can also purchase accessories or documentation items on the Internet at:

*<http://www.agilent.com/find>*

If you do not have access to the Internet, contact your field engineer.

---

**NOTE** In any correspondence or telephone conversation, refer to the product by its model number and full serial number. With this information, the Agilent representative can determine whether your unit is still within its warranty period.

---